



## Sequential driver



- Manual for installation and setup
- Handleiding voor installatie en setup
- Anleitung für Installation und Setup







## Sequential driver

EN

Part nr: 01-01-11-0080



Technical specifications and installation manual



This document contains detailed information about the KMS Sequential driver. Additional information, user manuals, wiring examples and software can be found on our website: [kms.vankronenburg.nl](http://kms.vankronenburg.nl) or on the software CD included with the ECU.

## 1. Package contents

- Sequential driver module
- CAN extension hub (2m)
- Sequential driver breakout loom
- Sequential driver module user manual



*Sequential driver breakout loom*



*CAN extension hub (2 metres)*

## 2. Installation of the KMS Sequential driver module

### 2.1 Installation notes

The KMS Sequential driver module is splash waterproof. However, it is best to place it in a dry place where temperatures don't exceed 65 °C.

**Warning:** do not place the Sequential driver and it's wires nearby any 'high powered' cables such as sparkplug leads, as it can cause electrical interference resulting in malfunction.

### 2.2 Wiring basics

Included with the KMS Sequential driver is a breakout wiring loom which consists out of a main connector with all wires connected. These wires are colour-coded according to their functions which can be found in the table on the next page.

Both the +12v power input and the power ground should be connected to the same stable power source as the ECU. It is highly recommended to install a 10A fuse on the +12v line to prevent further damage in case of a malfunction.

Connect the desired injector outputs to their corresponding injectors in either firing order or cylinder order. The resulting injection order and cylinder bank can later be set in the software (chapter 4: Software settings).

## 2.3 Main 18-pole connector

Connect to the Sequential driver module. Pin functions are as following:

Pin Nr. KMS	Colour	0.5mm	0.75mm	Details
1	Black		X	Ground
2	White		X	Injector output 8
3	White		X	Injector output 7
4	White		X	Injector output 6
5	White		X	Injector output 5
6	White		X	Injector output 4
7	White		X	Injector output 3
8	White		X	Injector output 2
9	White		X	Injector output 1
10	Red		X	12v power input
11	White	X		MD35 injector 1 input (MD35 pin 11)
12	Red		X	12v injector power output 1
13	White/Black	X		MD35 injector 2 input (MD35 pin 10)
14	Red		X	12v injector power output 2
15	-			-
16	Black	X		CAN ground (-)
17	Green	X		CAN low (-)
18	White	X		CAN high (+)

## 2.4 Wiring example scheme

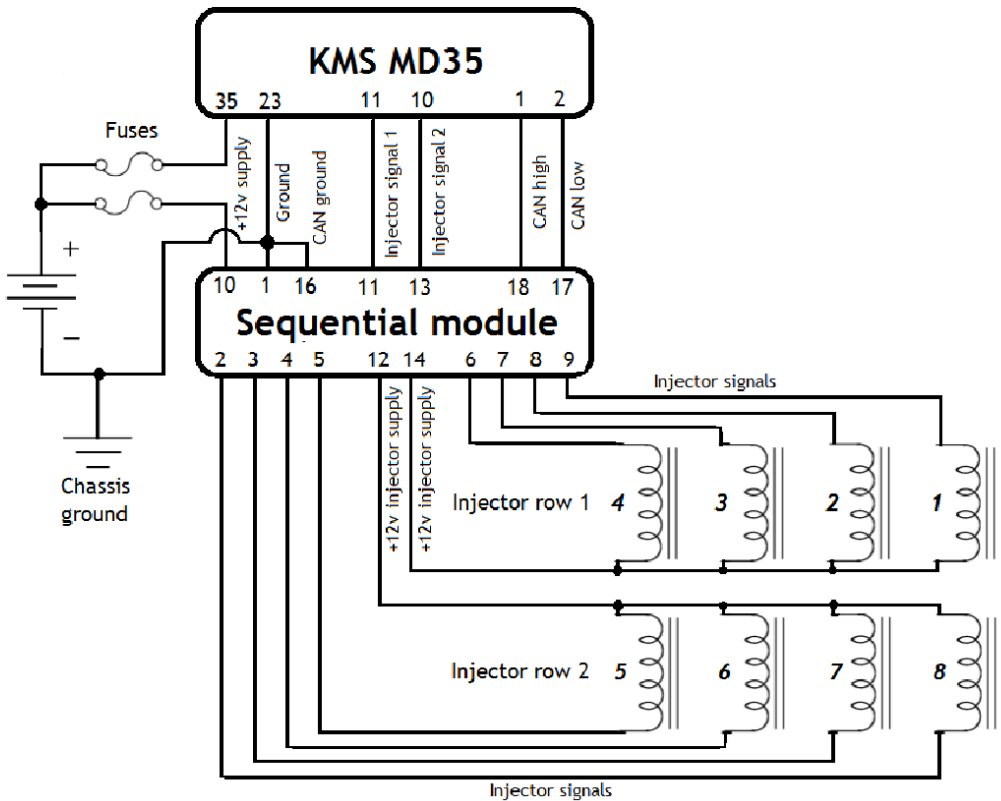

### KMS Sequential driver

### 3. Wiring of de CAN bus

The KMS Sequential driver module can communicate via CAN communication through the CAN bus (grey wire) which consists of two pair of twisted wires (green and white, red and black). Up to 10 CAN devices may be connected to the CAN bus. These devices must be placed within 0,5m of the CAN bus. See figure below for an example.

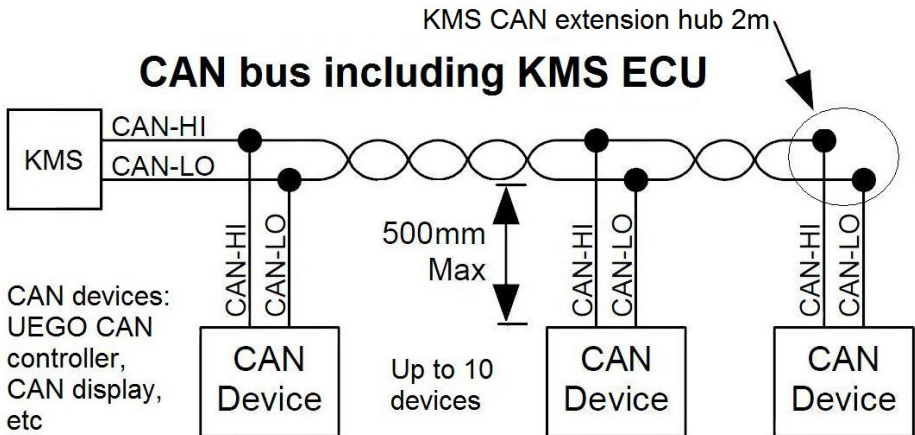



For all KMS CAN connections, the pin functions are as following:

Pin nr	Colour	Function
1	Red	12V supply
2	Black	Ground
3	White	CAN high (+)
4	Green	CAN low (-)

Male CAN connector front:

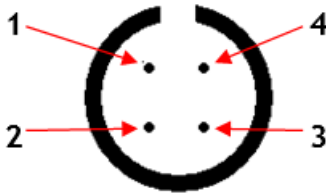

Female CAN connector front:

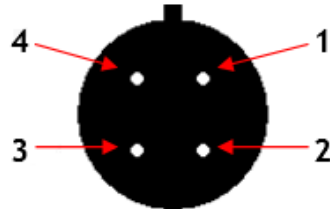

The CAN connection hub included in the package can be used to connect the KMS Sequential driver to the CAN bus. For every CAN device that's connected to the CAN bus, a CAN connection hub will be needed.

## 4. Software settings

The KMS Sequential Driver has to be set up in the KMS motormangement software. Version 4.21 or above is required for this function. Software updates can be found on the website [kms.vankronenburg.nl](http://kms.vankronenburg.nl).

**Warning:** To be able to fully use the KMS Sequential driver, a correct functioning camshaft position sensor is required. If a CAM pickup sensor is not available the module won't know if the cylinder is in the intake or combustion stroke.

To enable the Sequential driver module, go through the following steps:

1. Press F4 for options -> open 'options' -> 'RPM pickup'
2. Enable the CAM pickup sensor and enter the correct reference point
3. Enable the Sequential driver module and click 'Ok'
4. Set CAN bus speed at 1 Mhz fixed on all devices
5. Go to 'Injection settings' -> 'Sequential setup' for the driver settings

The screenshot shows the 'RPM pickup' configuration window. It has a title bar 'RPM pickup' and a button 'RPM Range'. The window is divided into three sections:

- Crank pickup:** An 'Enable' checkbox is checked. Below it, 'Sensor type' has three radio buttons: 'inductive' (selected), 'hall (falling edge)', and 'hall (rising edge)'. 'Crank type' is a dropdown menu showing '36 - 2 (4,5,6,8,10 cylinders)'. 'Reference point' is a numeric input set to '90' with 'Degrees BTDC' as the unit.
- Cam pickup:** An 'Enable' checkbox is checked. Below it, 'active' has two radio buttons: 'high' (selected) and 'low'. 'Cam Reference point' is a numeric input set to '40' with 'Degrees after TDC' as the unit.
- Sequential module on:** An 'Enable' checkbox is checked. To the right are 'Ok' and 'Cancel' buttons.

**Reminder:** When a KMS Sequential Driver is used it is necessary to set ALL CAN Bus devices to a communication speed of 1 Mhz (fixed)!

### KMS Sequential driver

When setting up the driver settings be sure to select the correct injection group. For single injecton-table tuned engines only injection group 1 should be connected ans setup. When two cylinder banks are separately tuned using both injection tables available on the MD35 ECU, the second bank can be setup in the ‘Sequential Setup’ menu found in the ‘Injection Settings’ menu.

Injection at output	of module	inj. group
1st injection at output	1	1
2nd injection at output	1	2
3rd injection at output	1	1
4th injection at output	1	2
5th injection at output	1	1
6th injection at output	1	2
7th injection at output	1	1
8th injection at output	1	1

For example: a sequential VAG VR6 setup.



## Sequentieedriver module

NL

Onderdeel nr: 01-01-11-0080



Technische specificaties en  
installatiehandleiding



Dit document bevat gedetailleerde informatie over de KMS Sequential driver. Aanvullende informatie, gebruikershandleidingen, bedradingsvoorbeelden en software kan worden gevonden op onze website [kms.vankronenburg.nl](http://kms.vankronenburg.nl) of op de software CD inbegrepen bij onze ECU's.

## 1. Pakket inhoud

- Sequential driver module
- CAN extensiekabel (2m)
- Sequential driver basiskabelboom
- Sequential driver module gebruikershandleiding



*Sequential driver basiskabelboom*



*CAN extensiekabel (2 meter)*

## 2. Installatie van de KMS Sequential driver module

### 2.1 Installatie opmerkingen

De KMS Sequential driver module is spatwaterdicht. Toch is het aanbevolen om deze op een droge plaats te monteren waar de temperatuur niet hoger dan 65 °C wordt.

**Let op:** plaats de Sequential driver module en de bijhorende bedrading uit de buurt van 'high powered' kabels (bougiekabels etc.) om elektrische storingen te voorkomen.

### 2.2 Bedrading basis

Bijgevoegd met de KMS Sequential driver is een basiskabelboom welke bestaat uit een hoofdstekker met alle bedrading aangesloten. Deze draden hebben een kleurcodering naar bijhorende functie staan in de tabel op de volgende pagina.

Om te beginnen moet de Sequential Driver op een stabiele +12v voeding en vaste massa worden aangesloten. De Sequential driver en de ECU dienen op dezelfde voedingsbron en massa te worden aangesloten om storingen te voorkomen. Het is aanbevolen om een 10 Ampere zekering op de +12v voedingskabel te installeren om in geval van kortsluiting verdere schade aan het systeem te voorkomen.

De KMS Sequential module stuurt de aangesloten injectoren aan door middel van massaschakelingen (-). Daarvoor is een constant +12v voeding naar alle injectoren nodig. Gebruik hoofdstekker pinnen 12 en 14, beide 0.75mm dikke rode draden. Sluit de gewenste injector uitgangen op hun respectievelijke injectoren aan volgens ontstekingsvolgorde of cilindervolgorde. De resulterende inspuitsvolgorde en cilinderbank kan later in de software worden ingesteld (hoofdstuk 4: Software instellingen).

## 2.3 18-polige hoofdstekker

Verbind met de Sequential driver module. Pinfuncties zijn als volgt:

Pin Nr. KMS	Kleur	0.5mm	0.75mm	Details
1	Zwart		X	Massa
2	Wit		X	Injector uitgang 8
3	Wit		X	Injector uitgang 7
4	Wit		X	Injector uitgang 6
5	Wit		X	Injector uitgang 5
6	Wit		X	Injector uitgang 4
7	Wit		X	Injector uitgang 3
8	Wit		X	Injector uitgang 2
9	Wit		X	Injector uitgang 1
10	Rood		X	12v voeding ingang
11	Wit	X		MD35 injector 1 ingang (MD35 pin 11)
12	Rood		X	12v injector voeding uitgang 1
13	Wit/Zwart	X		MD35 injector 2 ingang (MD35 pin 10)
14	Rood		X	12v injector voeding uitgang 2
15	-			-
16	Zwart	X		CAN massa (-)
17	Groen	X		CAN laag (-)
18	Wit	X		CAN hoog (+)

## 2.4 Bedrading voorbeeldschema

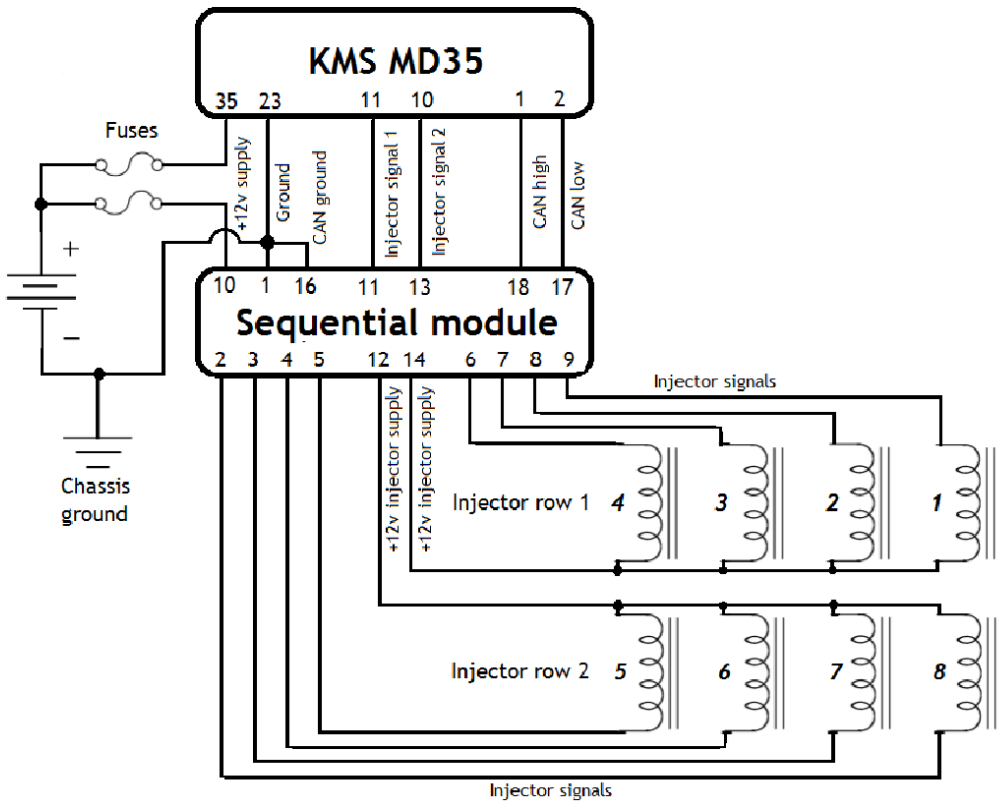

### KMS Sequential driver



### 3. Aansluiten op de CAN bus

De KMS Sequential driver module kan via CAN communicatie communiceren over de CAN bus (grijze kabel) welke bestaat uit twee paar (groen en wit, rood en zwart) 'getwiste' draden. Er mogen maximal 10 CAN apparaten worden aangesloten op de CAN bus. Deze apparaten moeten binnen 0,5m van de CAN bus staan. Zie het onderstaande figuur voor een voorbeeld:

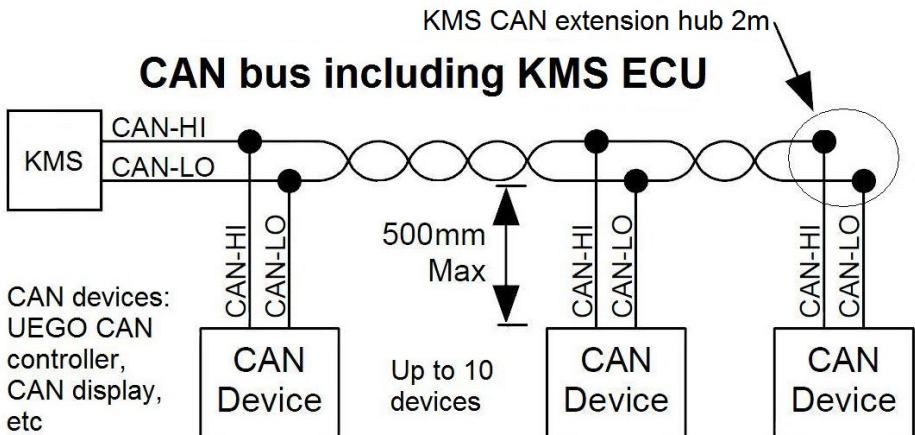

Voor alle KMS CAN verbindingen zijn de pinfuncties als volgt:

Pin nr	Kleur	Functie
1	Rood	12V voeding
2	Zwart	Massa
3	Wit	CAN hoog (+)
4	Groen	CAN laag (-)

Voorkant mannelijke stekker:

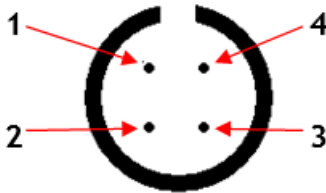

Voorkant vrouwelijke contra stekker:

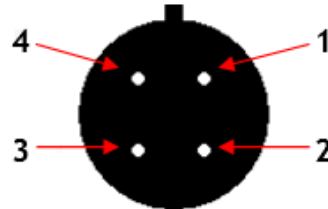

De CAN extensiekabel welke is bijgevoegd in het pakket kan worden gebruikt om de KMS Sequential driver module op de CAN bus aan te sluiten. Voor ieder apparaat dat wordt aangesloten op de CAN bus is een CAN extensiekabel benodigd.

## 4. Software instellingen

De KMS Sequential driver moet in de KMS Motormanagement software worden ingesteld. Versie 4.21 of hoger is benodigd voor deze functie. Softwareupdates kunnen op onze website worden gevonden: [kms.vankronenburg.nl](http://kms.vankronenburg.nl).

**Let op:** Om volledig gebruik te kunnen maken van de KMS Sequential driver is een correct functionerende nokkenaspositiesensor (CAM pickup sensor) een vereiste. Zonder CAM pickup sensor weet de module niet of de cilinder zich in inlaatslag of ontbrandingslag bevindt.

Doorloop de volgende stappen om de Sequential driver te activeren:

1. Druk op F4 voor opties -> open 'options' -> 'RPM pickup'
1. Activeer de CAM pickup sensor en voer het correcte refrenciepunt in
2. Activeer de Sequential driver module en druk op 'Ok'
3. Stel de CAN bus snelheid op 1 Mhz gefixeerd op alle apparaten
4. Open 'Injection settings' -> 'Sequential setup' voor de driver instellingen

**RPM pickup**

RPM Range

Enable  **Crank pickup**

Sensor type:  inductive  hall (falling edge)  hall (rising edge)

Crank type: 36 - 2 (4,5,6,8,10 cylinders)

Reference point: 90 Degrees BTDC

Enable  **Cam pickup**

active:  high  low

Cam Reference point: 40 Degrees after TDC

Enable  **Sequential module on**

**Herinnering:** Wanneer een KMS Sequential driver wordt gebruikt is het noodzaak om ALLE CAN bus apparaten op een communicatiesnelheid van 1 Mhz (fixed) in te stellen!

Bij het instellen van de driver instellingen is het selecteren van de juiste injectiegroep noodzakelijk. Voor setups die gebruik maken van een enkel inspuittabel moet alleen groep 1 worden gebruikt. Wanneer twee afzonderlijke cilinderbanken worden aangestuurd met de twee mogelijke inspuittabellen van de MD35 ECU, kan de tweede bank worden geselecteerd in het 'Sequential setup' menu onder 'Injection settings'.

**Injection settings**

Injection in 4 -stroke mode

**Overrun fuel cut**  
on at RPM >: 1600 + TPS <: 0,0

**Sequential setup**

1st injection at output	1	of module	1	inj. group	1
2nd injection at output	2	of module	1	inj. group	2
3rd injection at output	3	of module	1	inj. group	1
4th injection at output	4	of module	1	inj. group	2
5th injection at output	5	of module	1	inj. group	1
6th injection at output	6	of module	1	inj. group	2
7th injection at output	-	of module	1	inj. group	1
8th injection at output	-	of module	1	inj. group	1

Ok

**Voorbeeld: een sequentiele VAG VR6 setup.**

## Sequential-treiber Modul

DE

Teilenummer: 01-01-11-0080



Technische Information und Installationsanleitung



**Kronenburg Management Systems**

















## Kronenburg Management Systems

Spaarpot-Oost 19  
5667 KT Geldrop  
The Netherlands

T +31 (0)40 285 40 64  
F +31 (0)40 286 77 65  
E [info@van-kronenburg.nl](mailto:info@van-kronenburg.nl)

*Please visit our website for more information, manuals, software and prices:  
[kms.vankronenburg.nl](http://kms.vankronenburg.nl)*